

THREADED AND SEAL WELDED

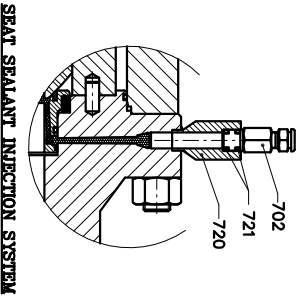

SIZE	24"
DN	600
DE	589
B	1397
Valve weight kg~	4400

THREADED AND SEAL WELDED

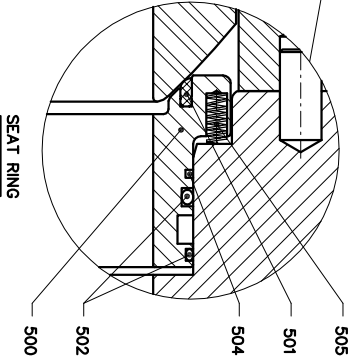
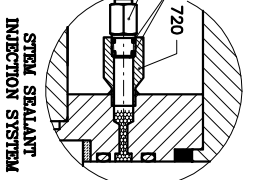
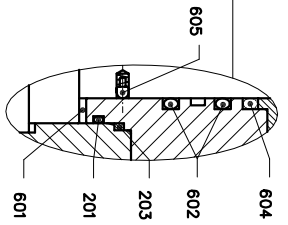
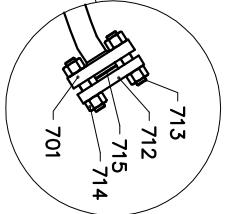
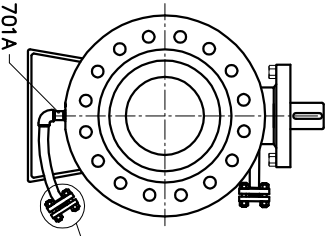
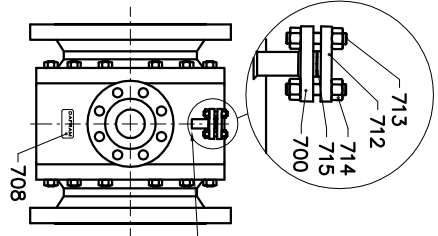

DESIGN TEMP. :
-10° C to +82° C

DESIGN acc.to
ASME B16.34 and API6D

PAINING TO :
V-9 cycle-1 RAL: White 9010
Dafraim PRO 7.5H: PAG. 235

DN>=32 , MARKING:



FIRE SAFE VALVES
ACCORDING TO BS 6755 P.2
or API 607 5th edition

STD SMAE PARTS	Pos.	PART NAMES	MATERIALS
	721	O-RING	VITON GLT AED
	720	EXTENSION	ASTM A350 gr. LF2
	715	SPIRAL WOUND GASKET	316 STAINLESS STEEL+EXPANDED GRAPHITE
	714	NUTS	ASTM A194 gr. 7
	713	BOLTS	ASTM A320 gr. L7
	712	BLIND FLANGE	ASTM A350 gr. LF2
	708	IDENTIFICATION PLATE	STAINLESS STEEL
	706	EYE BOLT	GALVANIZED CARBON STEEL
	705	VALVE SUPPORT	CARBON STEEL
	703	STEM GREASE FITTING	ASTM A350 gr. LF2
	702	SEAT GREASE FITTING	ASTM A350 gr. LF2
	701A	NIPPLE 1"NP1	ASTM A350 gr. LF2
	701	DRAIN FLANGE	ASTM A350 gr. LF2
	700	BLEED FLANGE	ASTM A350 gr. LF2
	606	STEM KEY	CARBON STEEL
	605	ANTISTATIC DEVICE	316 STAINLESS STEEL
	604	UPPER STEM SEAL	EXPANDED GRAPHITE
	602	STEM O-RING	VITON GLT AED
	601	LOWER STEM SEAL	NYLON
	600	STEM	ASTM A29 4140+30µm ENP
	505	COIL SPRINGS	INCONEL X-750
	504	FIRE-SAFE SEAT SEAL	EXPANDED GRAPHITE
	502	SEAT O-RING	VITON GLT AED
	501	SEAT	NYLON
	500	SEAT RING	ASTM A350 gr. LF2+30µm ENP
	404	BALL ANTI-FRICTION BEARING	PTFE
	403	BEARING RETAINER PIN	316 STAINLESS STEEL
	402	BEARING RETAINER	ASTM A350 gr. LF2
	401	BALL BEARING	CARBON STEEL + PTFE
	400	BALL	ASTM A350 gr. LF2+30µm ENP
	207	ADAPTER FLANGE SCREWS	A2/70
	206	ADAPTER FLANGE	ASTM A350 gr. LF2
	205	TOP FL. PIN	CARBON STEEL
	204	TOP FL. SCREWS	A2/70
	203	TOP FL. SECOND. GASKET	EXPANDED GRAPHITE
	201	TOP FL. PRIM. GASKET	VITON GLT AED
	200	TOP FLANGE	ASTM A350 gr. LF2
	106	NUTS	ASTM A194 gr. 7
	105	BOLTS	ASTM A320 gr. L7
	104	SECONDARY BODY GASKET	EXPANDED GRAPHITE
	102	PRIMARY BODY GASKET	VITON GLT AED
	101	BODY CONNECTOR	ASTM A350 gr. LF2
	100	VALVE BODY	ASTM A350 gr. LF2

Pos.	Accessories:			
Valve type	Size/DN	Class	End Type	Material
F6FP	24"/600	600/PN100	ASME B16.5 RF	LF2/LF2+ENP
Confirmation NR.	Customer	Your order		
Project Name :				
Accessories:				
REV.	ISSUED BY	CHECKED BY	PASSED BY	DATE
DAFRAM S.p.A. VALVOLE A SFERA MILANO DRAWING AB011620-1/3				